

## MOSFET Integrated Smart Photoflash Capacitor Charger with IGBT Driver

### General Description

The RT9595 is a complete photoflash module solution for digital and film cameras. It is targeted for applications that use 2 to 3 AA batteries or 1 Lithium-Ion battery. The RT9595 adopts fly back topology which use constant primary peak current and zero secondary valley current to charge photoflash capacitor quickly and efficiently. The built-in 45V MOSFET allows flexibility in transformer design and simplifies the PCB layout. The RT9595 also integrate an IGBT driver for igniting photoflash tube. Only a few external components are required, which greatly reduce the PCB space and cost. The RT9595 is available in the WDFN-10L 3x3 package.

### Ordering Information

RT9595 □ □

- Package Type  
QW : WDFN-10L 3x3 (W-Type)
- Lead Plating System  
G : Green (Halogen Free and Pb Free)

Note :

Richtek products are :

- ▶ RoHS compliant and compatible with the current requirements of IPC/JEDEC J-STD-020.
- ▶ Suitable for use in SnPb or Pb-free soldering processes.

### Marking Information

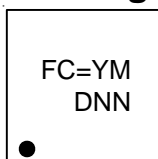

FC= : Product Code  
YMDNN : Date Code

### Features

- 45V MOSFET Integrated
- Charges any Size Photoflash Capacitor
- Adjustable Input Current
- Adjustable Output Voltage
- Charge Complete Indicator
- Built-In IGBT Driver for IGBT Application
- Constant Peak Current Control
- Over Voltage Protection
- 10-Lead WDFN Package
- RoHS Compliant and Halogen Free

### Applications

- Digital Still Camera
- Film Camera Flash Unit
- Camera Phone Flash

### Pin Configurations

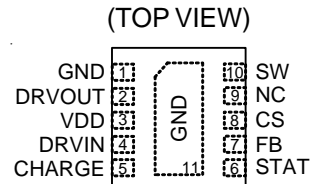

WDFN-10L 3x3

Typical Application Circuit

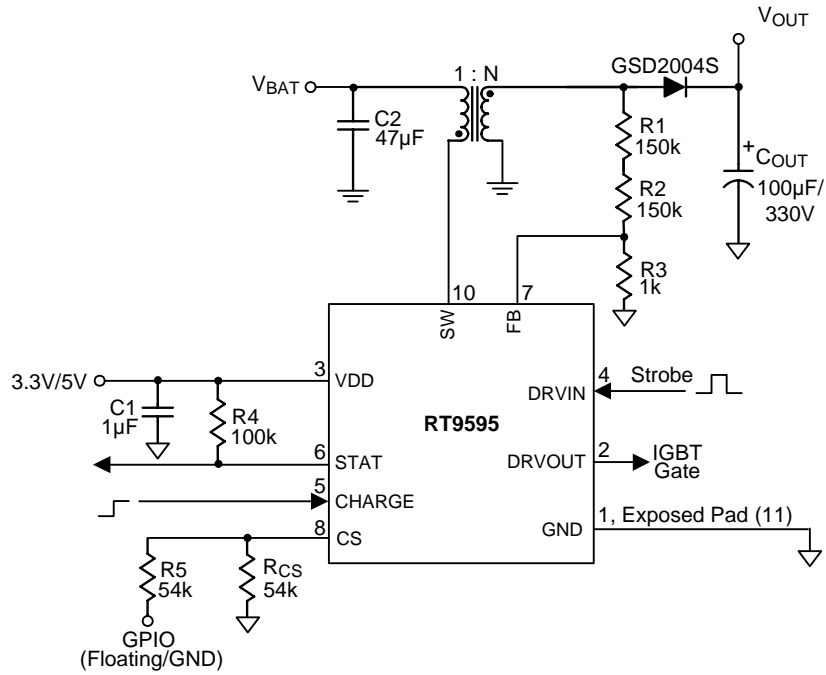

Function Block Diagram

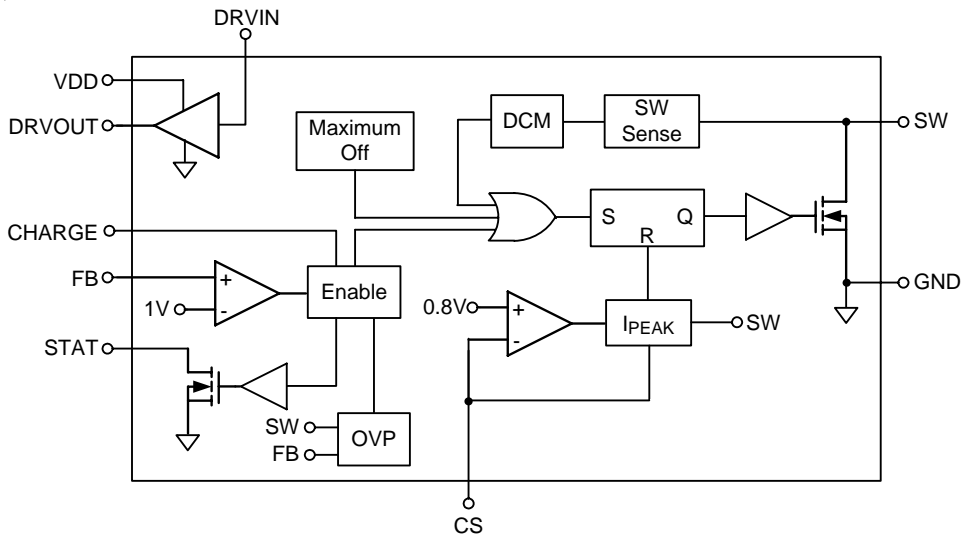

**Functional Pin Description**

Pin No.	Pin Name	Pin Function
1, 11 (Exposed Pad)	GND	Ground. The exposed pad must be soldered to a large PCB and connected to GND for maximum power dissipation.
2	DRVOUT	IGBT Driver Output Pin.
3	VDD	Power Input Pin.
4	DRVIN	IGBT Driver Input Pin.
5	CHARGE	Charge Enable Pin. The charge function is executed when CHARGE pin is set from Low to High. The chip is in Shutdown mode when CHARGE pin is set to Low.
6	STAT	Charge Status Output. Open Drain output. When target output voltage is reached, N-MOSFET turns on. This pin needs a pull up resistor.
7	FB	Feedback Voltage Pin.
8	CS	Input Current Setting Pin.
9	NC	No Internal Connection.
10	SW	N-MOSFET Switching Node.

**Absolute Maximum Ratings** (Note 1)

- Supply Voltage,  $V_{DD}$  ----- 6V
- Built-in N-Channel Enhancement MOSFET
  - Drain-Source Voltage ----- 45V
  - CS, CHARGE, DRVIN, DRVOUT, STAT, FB ----- 6V
  - SW Pulse Current (Pulse Width  $\leq 1\mu s$ ) ----- 4A
  - SW Continuous Current ----- 2A
- Power Dissipation,  $P_D$  @  $T_A = 25^\circ C$ 
  - WDFN-10L 3x3 ----- 1.667W
- Package Thermal Resistance (Note 2)
  - WDFN-10L 3x3,  $\theta_{JA}$  -----  $60^\circ C/W$
  - WDFN-10L 3x3,  $\theta_{JC}$  -----  $7.5^\circ C/W$
- Junction Temperature -----  $150^\circ C$
- Lead Temperature (Soldering, 10 sec.) -----  $260^\circ C$
- Storage Temperature Range -----  $-65^\circ C$  to  $150^\circ C$
- ESD Susceptibility (Note 3)
  - HBM (Human Body Mode) ----- 2kV
  - MM (Machine Mode) ----- 200V

**Recommended Operating Conditions** (Note 4)

- Drain Source Voltage ----- 40V
- Junction Temperature Range -----  $-40^\circ C$  to  $125^\circ C$
- Ambient Temperature Range -----  $-40^\circ C$  to  $85^\circ C$

## Electrical Characteristics

( $V_{DD} = 3.3V$ ,  $T_A = 25^\circ C$ , unless otherwise specified)

Parameter	Symbol	Test Conditions	Min	Typ	Max	Unit
VDD Operating Voltage	$V_{DD}$		2.9	--	5.5	V
Switch Off Current	$I_{VDD\_SW\_OFF}$	$V_{FB} = 1.1V$	--	1	10	$\mu A$
Shutdown Current	$I_{OFF}$	CHARGE pin = 0V	--	0.01	1	$\mu A$
FB Voltage	$V_{FB}$		0.985	1	1.015	V
Line Regulation	$ \Delta V_{FB} $	$2.9V < V_{DD} < 5.5V$	--	--	10	mV
STAT Open Drain $R_{DS(ON)}$			--	11	19	$\Omega$
Charge Enable High	$V_{CEH}$		1.3	--	--	V
Charge Enable Low	$V_{CEL}$		--	--	0.4	V
<b>Built-In N-Channel Enhancement MOSFET</b>						
Drain-Source On-Resistance	$R_{DS(ON)}$	$V_{DD} = 3.3V, I_D = 10mA$	--	0.3	0.4	$\Omega$
Maximum Off Time During Pre-Charge			--	9	--	$\mu s$
Minimum Off Time			--	400	--	ns
<b>IGBT Driver</b>						
DRVIN Trip Point			0.8	1.5	2.4	V
DRVOUT On Resistance to $V_{DD}$		$V_{DD} = 3.3V$	--	6	--	$\Omega$
DRVOUT On Resistance to GND		$V_{DD} = 3.3V$	--	11	--	$\Omega$
Propagation Delay (Rising)			--	20	--	ns
Propagation Delay (Falling)			--	200	--	ns

**Note 1.** Stresses beyond those listed "Absolute Maximum Ratings" may cause permanent damage to the device. These are stress ratings only, and functional operation of the device at these or any other conditions beyond those indicated in the operational sections of the specifications is not implied. Exposure to absolute maximum rating conditions may affect device reliability.

**Note 2.**  $\theta_{JA}$  is measured at  $T_A = 25^\circ C$  on a high effective thermal conductivity four-layer test board per JEDEC 51-7.  $\theta_{JC}$  is measured at the exposed pad of the package.

**Note 3.** Devices are ESD sensitive. Handling precaution is recommended.

**Note 4.** The device is not guaranteed to function outside its operating conditions.

**Typical Operating Characteristics**

**Switching**

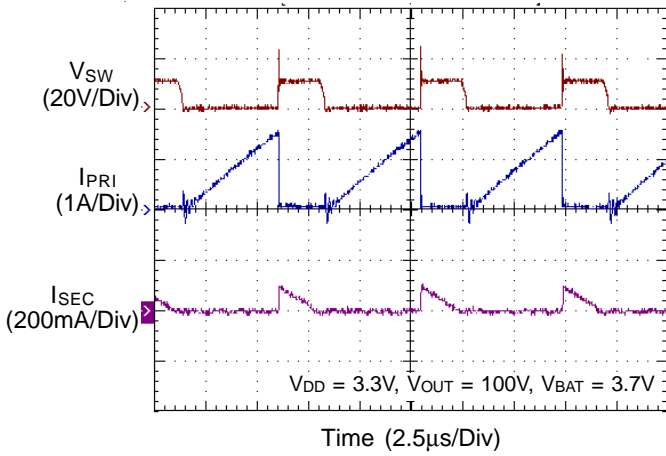

**Switching**

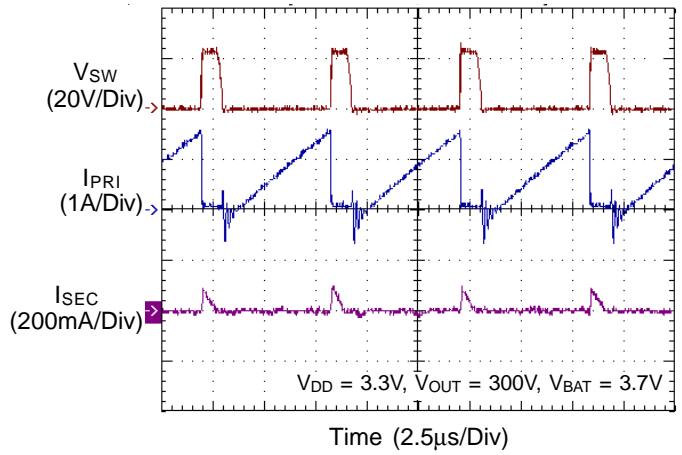

**Charging Time**

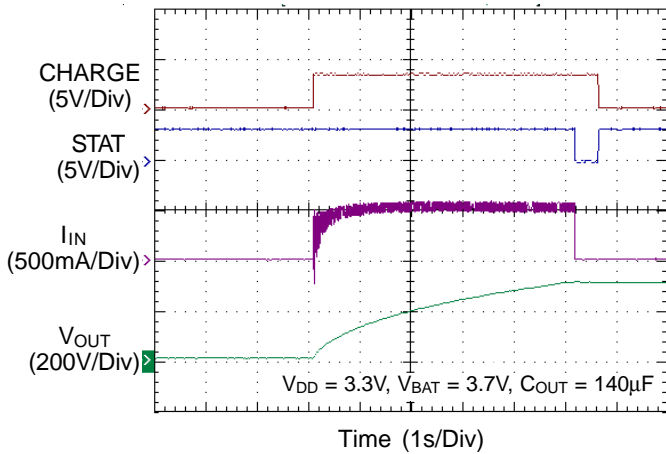

**Charge Time vs. V<sub>BAT</sub>**

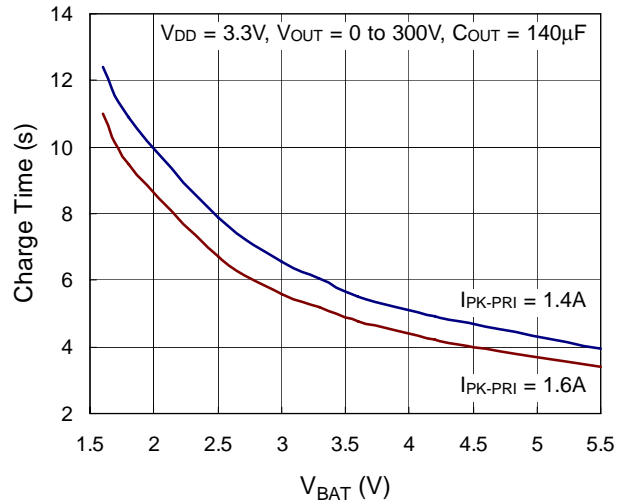

**Charge Time vs. V<sub>BAT</sub>**

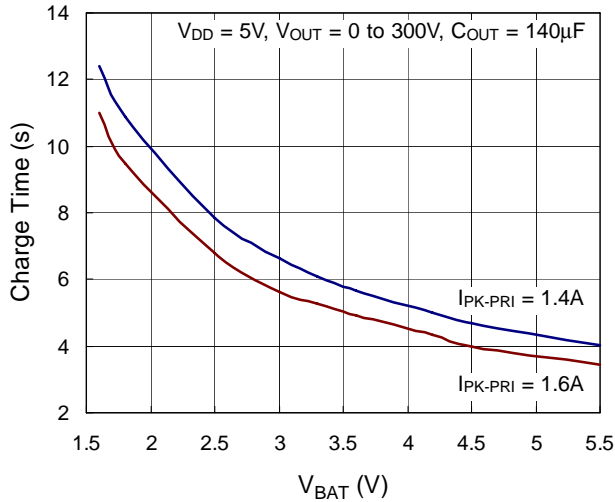

**Output Voltage vs. V<sub>BAT</sub>**

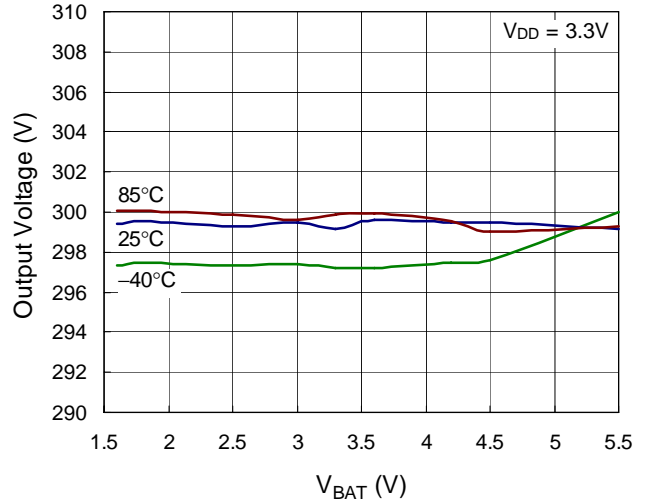

### Application Information

The RT9595 integrates a constant peak current controller for charging photoflash capacitor and an IGBT driver for igniting flash tube. The photoflash capacitor charger uses constant primary peak current and SW falling control to efficiently charge the photoflash capacitor.

Pulling the CHARGE pin high will initiate the charging cycle. However, the CHARGE signal must come from low to high after  $V_{DD} > 2V$  for at least  $1\mu s$  delay time.

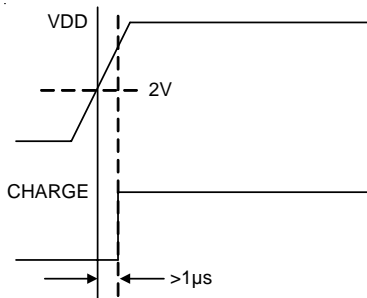

Figure 1. Recommend Charge Timing Chart

During MOSFET on period, the primary current ramps up linearly according to  $V_{BAT}$  and primary inductance. A resistor connecting from CS pin to GND determines the primary peak current.

During the MOSFET off period, the energy stored in the flyback transformer is boosted to the output capacitor. The secondary current decreases linearly at a rate determined by the secondary inductance and the output voltage (neglecting the voltage drop of the diode).

The SW pin monitors the secondary current. When the secondary current drops to 0A, SW voltage falls, and then the MOSFET on period starts again. The charging cycle repeats itself and charges the output capacitor. The output voltage is sensed by a voltage divider connecting to the anode of the rectifying diode. When the output voltage reaches the desired voltage set by the resistor divider, the charging block will be disabled and charging will be stopped.

Then STAT pin will be pulled low to indicate the complete charging.

The voltage-sensing path will be cut off when charging is completed to minimize the output voltage decay. Both the CHARGE and STAT pins can be easily interfaced to a microprocessor in a digital system.

### Charge Current Setting

The RT9595 simply adjusts peak primary current by a resistor  $R_{CS}$  connecting to the CS pin as shown in the Function Block Diagram.  $R_{CS}$  determines the peak current of the primary N-MOSFET according to the following equation :

$$I_{PK\_PRI} = \frac{40000}{R_{CS}} \quad (A)$$

Where the  $I_{PK\_PRI}$  is the primary peak current. Users could select appropriate  $R_{CS}$  according to the battery capability and required charging time.

### Transformer

The flyback transformer should be appropriately designed to ensure effective and efficient operation.

#### 1. Turns Ratio

The turns ratio of transformer (N) should be high enough so that the absolute maximum voltage rating for the internal N-MOSFET drain to source voltage is not exceeded. Choose the minimum turns ratio according to the following formula :

$$N_{MIN} \geq \frac{V_{OUT}}{40 - V_{BAT}}$$

Where :

$V_{OUT}$  : Target Output Voltage

$V_{BAT}$  : Battery Voltage

#### 2. Primary Inductance

Each switching cycle, energy transferred to the output capacitor is proportional to the primary inductance for a constant primary current. The higher the primary inductance, the higher the charging efficiency. Besides, to ensure enough off time for the output voltage sensing, the primary inductance should be high enough according to the following formula :

$$L_{PRI} \geq \frac{400 \times 10^{-9} \times V_{OUT}}{N \times I_{PK\_PRI}}$$

$V_{OUT}$  : Target Output Voltage

N : Transformer turns ratio

$I_{PK\_PRI}$  : Primary peak current

**3. Leakage Inductance**

The leakage inductance of the transformer results in the first spike voltage when N-MOSFET turns off. The spike voltage is proportional to the leakage inductance and inductor peak current. The spike voltage must not exceed the dynamic rating of the N-MOSFET drain to source voltage (45V).

**4. Transformer Secondary Capacitance**

Any capacitance on the secondary can severely affect the efficiency. A small secondary capacitance is multiplied by  $N^2$  when reflected to the primary will become large.

This capacitance forms a resonant circuit with the primary leakage inductance of the transformer. Therefore, both the primary leakage inductance and secondary side capacitance should be minimized.

**Rectifying Diode**

The rectifying diode should be with short reverse recovery time (small parasitic capacitance). Large parasitic capacitance increases switching loss and lowers charging efficiency.

In addition, the peak reverse voltage and peak current of the diode should be sufficient.

The peak reverse voltage of the diode can be calculated as following Equation :

$$V_{PK-R} \approx V_{OUT} + (N \times V_{BAT})$$

The peak current of the diode equals the primary peak current divided by the transformer turn ratio as the following equation :

$$I_{PK-SEC} = \frac{I_{PK-PRI}}{N}$$

Where : N is the transformer turns ratio.

**Output Voltage Setting**

The RT9595 senses the output voltage by a voltage divider connecting to the anode of the rectifying diode during OFF time as shown in Figure 2. This eliminates power loss at voltage-sensing circuit when charging is completed. R1 to R2 ratio determines the output voltage as shown in the typical application circuit. The feedback reference voltage is 1V.

If  $V_{OUT} = 300V$ , according the following equation :

$$V_{OUT} = V_{FB} \times (1 + \frac{R1+R2}{R3}) \text{ and } \frac{R1+R2}{R3} = 299$$

It is recommended to set  $R3 = 1k\Omega$  and  $R1 = R2 = 150k\Omega$  for reducing parasitic capacitance coupling effect of the FB pin. R1 and R2 **MUST** be greater than 0805 size resistor for enduring secondary HV. Another sensing method is to sense the output voltage directly as shown in Figure 3.

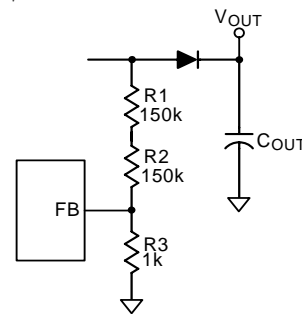

Figure 2. Sensing Anode of Diode

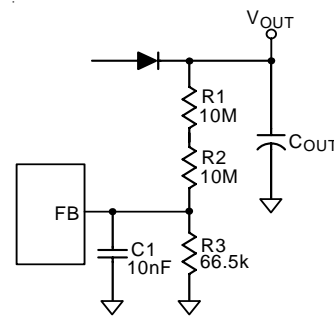

Figure 3. Sensing Output Voltage

**Over Voltage Protection (OVP)**

The RT9595 provides over voltage protection (OVP) function. In the typical application circuit, if the FB resistor R1, R2 or R3 is open, the FB voltage will be pulled low or floating. In this condition, when the CHARGE pin goes High, the RT9595 begins switching, once the SW voltage rises to higher than 10V, the OVP function will be triggered.

The avoiding OVP battery voltage upper limit is shown as the following equation :

$$V_{BAT} < 10V - \frac{0.16 \times (R1+R2+R3)}{N \times R3}$$

N : Transformer turns ratio.



### False Triggering Prevention

The RT9595 includes a mechanism to prevent false triggering of DRVOUT while the device is still in charging mode.

With this mechanism, the DRVIN pin is only allowed to trigger DRVOUT when the CHARGE pin is low.

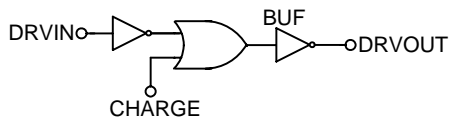

Figure 4. Trigger Logic

### Thermal Considerations

For continuous operation, do not exceed absolute maximum operation junction temperature. The maximum power dissipation depends on the thermal resistance of IC package, PCB layout, the rate of surroundings airflow and temperature difference between junction to ambient. The maximum power dissipation can be calculated by following formula :

$$P_{D(MAX)} = (T_{J(MAX)} - T_A) / \theta_{JA}$$

Where  $T_{J(MAX)}$  is the maximum operation junction temperature ,  $T_A$  is the ambient temperature and the  $\theta_{JA}$  is the junction to ambient thermal resistance.

For recommended operating conditions specification, the maximum junction temperature is 125°C. The junction to ambient thermal resistance  $\theta_{JA}$  is layout dependent. For WDFN-10L 3x3 packages, the thermal resistance  $\theta_{JA}$  is 60°C/W on the standard JEDEC 51-7 four layers thermal test board. The maximum power dissipation at  $T_A = 25^\circ\text{C}$  can be calculated by following formula :

$$P_{D(MAX)} = (125^\circ\text{C} - 25^\circ\text{C}) / (60^\circ\text{C/W}) = 1.667\text{W for WDFN-10L 3x3 packages}$$

The maximum power dissipation depends on operating ambient temperature for fixed  $T_{J(MAX)}$  and thermal resistance  $\theta_{JA}$ . For WDFN-10L 3x3 package, the Figure 5 of derating curves allows the designer to see the effect of rising ambient temperature on the maximum power allowed.

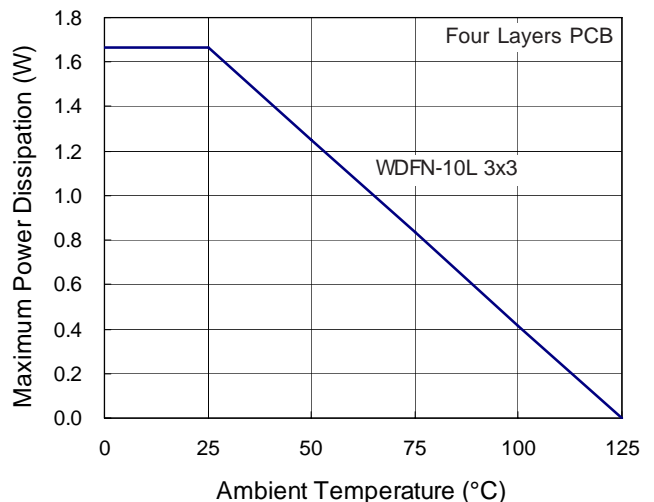

Figure 5. Derating Curve of Maximum Power Dissipation

### Layout Consideration

For best performance, the following guidelines should be strictly followed.

- ▶ Both of primary and secondary power paths should be as short as possible.
- ▶ Place the  $R_{CS}$  as close to chip as possible. The GND side of  $R_{CS}$  should be directly connected to ground plane to avoid noise coupling.
- ▶ Keep FB node area small and far away from nodes with voltage switching to reduce parasitic capacitance coupling effect.
- ▶ The PGND should be connected to  $V_{BAT}$  ground plane to reduce switching noise.

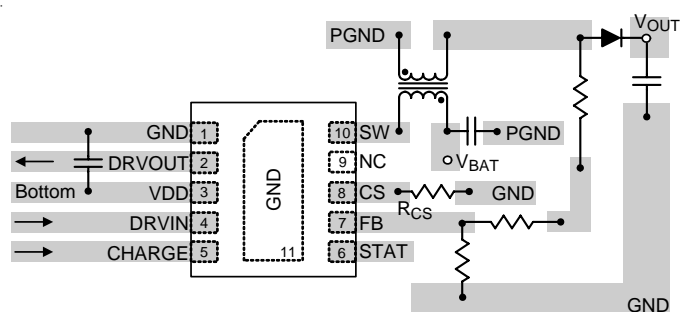
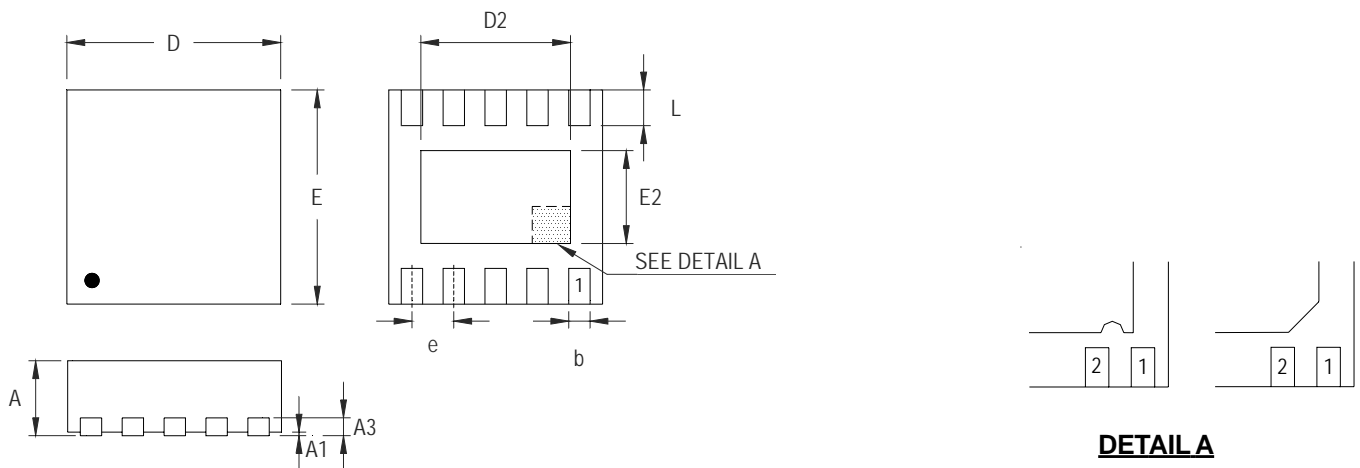

Figure 6. Recommended Layout Guideline



**Outline Dimension**



**DETAIL A**

Pin #1 ID and Tie Bar Mark Options

Note : The configuration of the Pin #1 identifier is optional, but must be located within the zone indicated.

Symbol	Dimensions In Millimeters		Dimensions In Inches	
	Min	Max	Min	Max
A	0.700	0.800	0.028	0.031
A1	0.000	0.050	0.000	0.002
A3	0.175	0.250	0.007	0.010
b	0.180	0.300	0.007	0.012
D	2.950	3.050	0.116	0.120
D2	2.300	2.650	0.091	0.104
E	2.950	3.050	0.116	0.120
E2	1.500	1.750	0.059	0.069
e	0.500		0.020	
L	0.350	0.450	0.014	0.018

**W-Type 10L DFN 3x3 Package**

**Richtek Technology Corporation**

5F, No. 20, Taiyuen Street, Chupei City  
 Hsinchu, Taiwan, R.O.C.  
 Tel: (8863)5526789

Richtek products are sold by description only. Richtek reserves the right to change the circuitry and/or specifications without notice at any time. Customers should obtain the latest relevant information and data sheets before placing orders and should verify that such information is current and complete. Richtek cannot assume responsibility for use of any circuitry other than circuitry entirely embodied in a Richtek product. Information furnished by Richtek is believed to be accurate and reliable. However, no responsibility is assumed by Richtek or its subsidiaries for its use; nor for any infringements of patents or other rights of third parties which may result from its use. No license is granted by implication or otherwise under any patent or patent rights of Richtek or its subsidiaries.